



The Institution of Engineers Pakistan
in collaboration with
NED University of Engineering & Technology



6th INTERNATIONAL CIVIL ENGINEERING CONGRESS (ICEC 2013)

Seismic Evaluation of an Existing Building Using Performance Based Design

By

Sammar Iqbal

Junior Design Engineer, EA Consulting Pvt. Ltd., Karachi

Introduction

- This paper is based on the seismic evaluation of an existing building
- Seismic evaluation is done to check the vulnerability of the given building against the seismic forces
- Performance Based Design (PBD) approach is employed for seismic evaluation of the building

Need of Evaluation

- Earthquake, a natural phenomenon
- The forces generated by earthquake causes potential hazard to buildings and in evidently to human life
- Therefore, seismic evaluation is required to understand the behaviour of buildings under such forces

Seismic Evaluation

- Is the process of identifying any potential risks as posed by specific building and determining whether during the occurrence of earthquake events will the building be able to resist it or not

Performance Based Design

- Is an approach that determines the performance of a structure under the influence of seismic loads
- Considers the potential hazards likely to be experienced by the structure during an earthquake
- Provides a method for determining acceptable levels of earthquake damage i.e. performance levels
- Performance level is the selection of acceptable damage state for any structure

Performance Levels

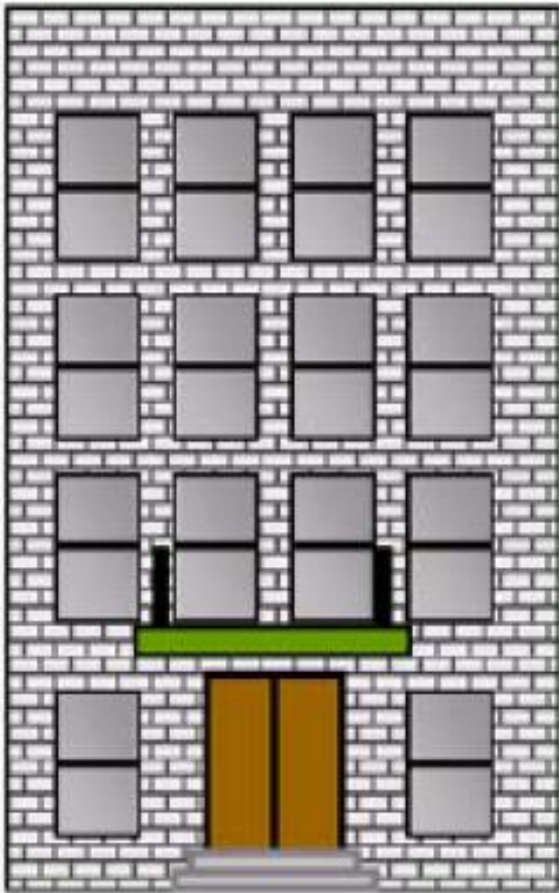

Immediate Occupancy

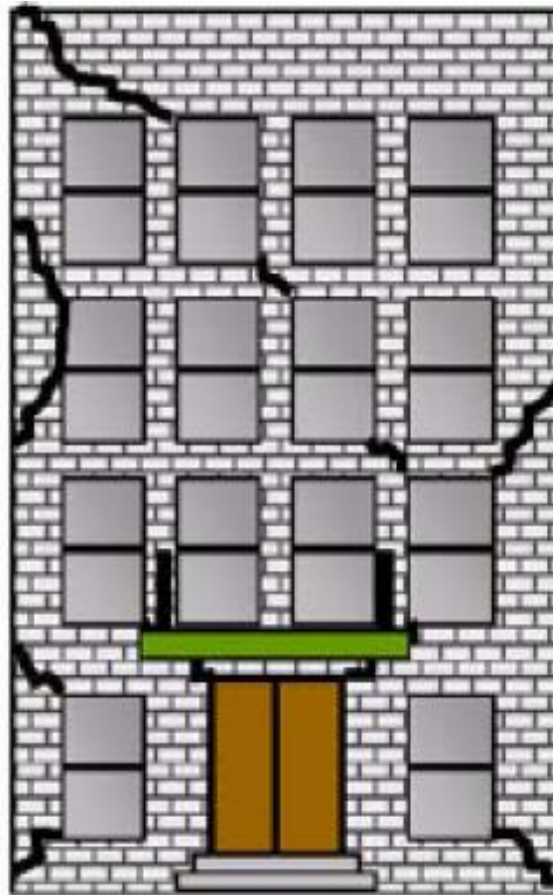

Life Safety

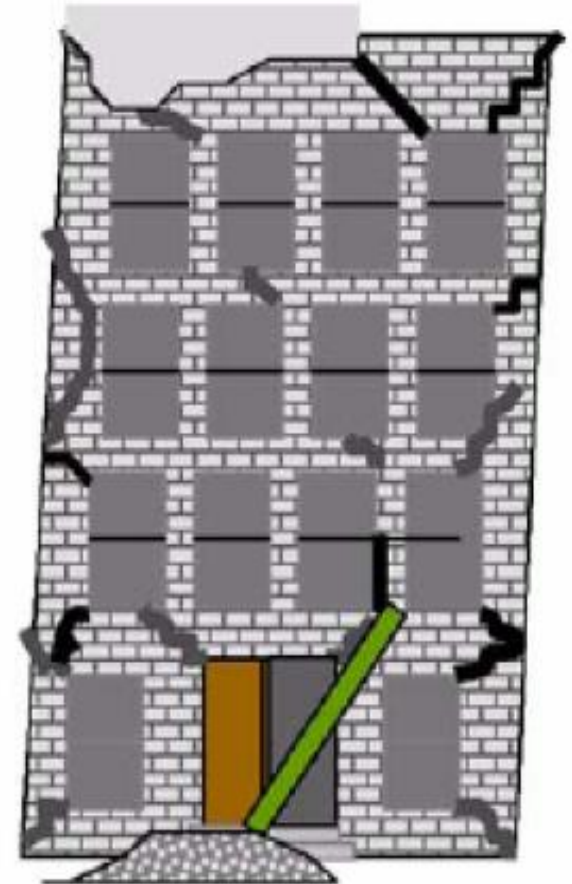

Collapse Prevention

Methodology

- The given building was evaluated for Seismic Zone 3 with performance level Life Safety (LS)
- ASCE 31-03 and ASCE 41-06 were used as guidelines for the analysis
- Seismic load parameters and load combinations were taken from UBC-97
- Linear Static Procedure and Push Over Static Procedure have been used for linear and non-linear analysis respectively
- Cross sectional details of beams, columns and slabs were extracted from the available drawings

Methodology

- Infill walls were modelled by equivalent strut method
- In linear analysis to determine the potential deficiencies of the structure, checks were performed as defined in ASCE 31-03
- Deficient members were further analyzed by considering nonlinearity of the section
- Retrofitting technique was proposed for the members not meeting the required performance level

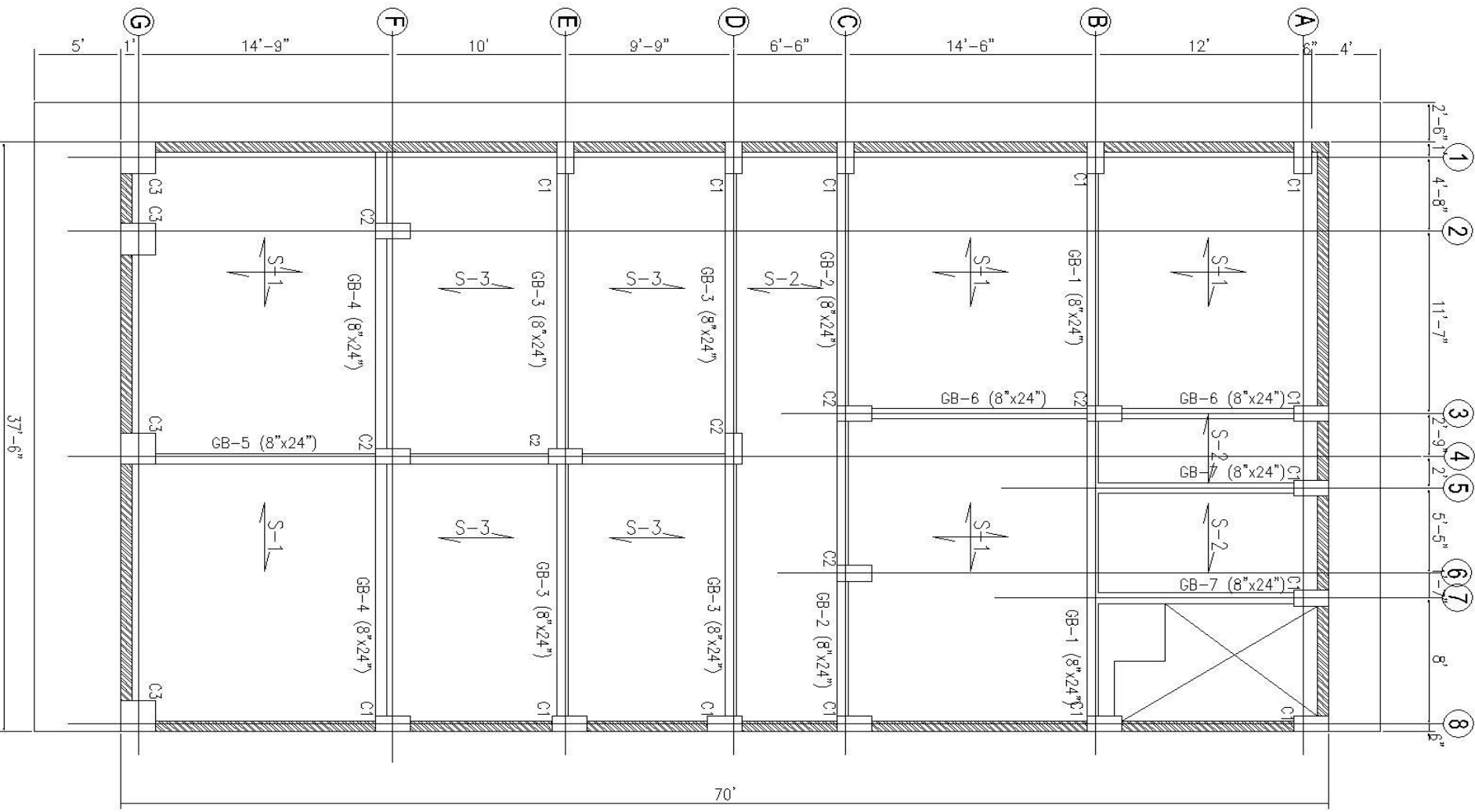

Ground Floor Framing Plan

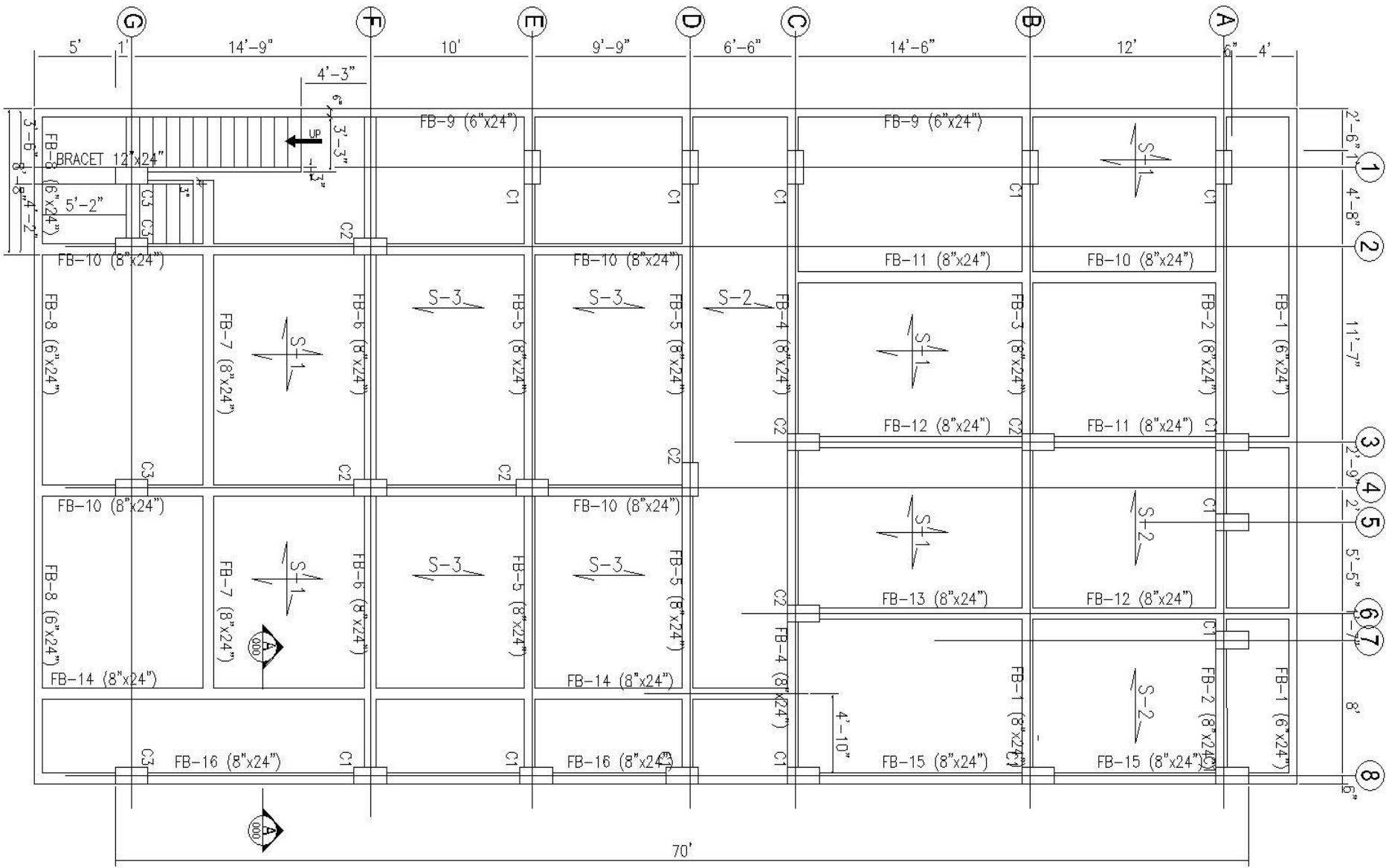

Typical Floor Framing Plan

ARCHITECTURAL DETAIL:	
Covered Area	300 Sq. Yds
Total number of story	6
Basement	Available
Total number of columns	25
Square shape columns (2'-0" X 2'-0")	4
Rectangular shape column (1'-0" X 2'-0")	21

STRUCTURE DETAIL:	
Column sections:	
C1 (1'-0" X 2'-0")	10#5
C3 (2'-0" X 2'-0")	12#8
Beam sections:	
B1 (6" X 24")	2#5 top and bottom
B2 (8" X 24")	3#5 top and bottom
Slab :Thickness	6" TH.

Modeling Parameters

Parameters	Values	Reference(s)
f'_c	3.75 ksi	From available drawings
F_y	60 ksi	From available drawings
Frame type	Ordinary moment resisting frame	Assumption
Over strength factor, R	3.5	UBC 97 Table 16-N
Importance factor, I	1	UBC 97 Table 16-K
C_t	0.03	
Seismic zone	Zone 3	UBC 97 Table 16-I
Seismic zone factor	0.30	UBC 97 Table 16-I
Soil Profile	Sc(Very Dense Soil and Soft Rock)	Assumption
Seismic co-efficient, (C_a)	0.33	UBC 97 Table 16-Q
Seismic co-efficient, (C_v)	0.45	UBC 97 Table 16-R

Infill Walls As An Equivalent Strut

- Infill walls provide stiffness
- Modelled as one or two diagonal strut i.e. as compression member as in block masonry or both as in RCC wall
- Transfer load diagonally when subjected to lateral forces
- Numerical modelling for infill walls allows an assessment of performance of building
- Infill walls are modelled using Equivalent strut method

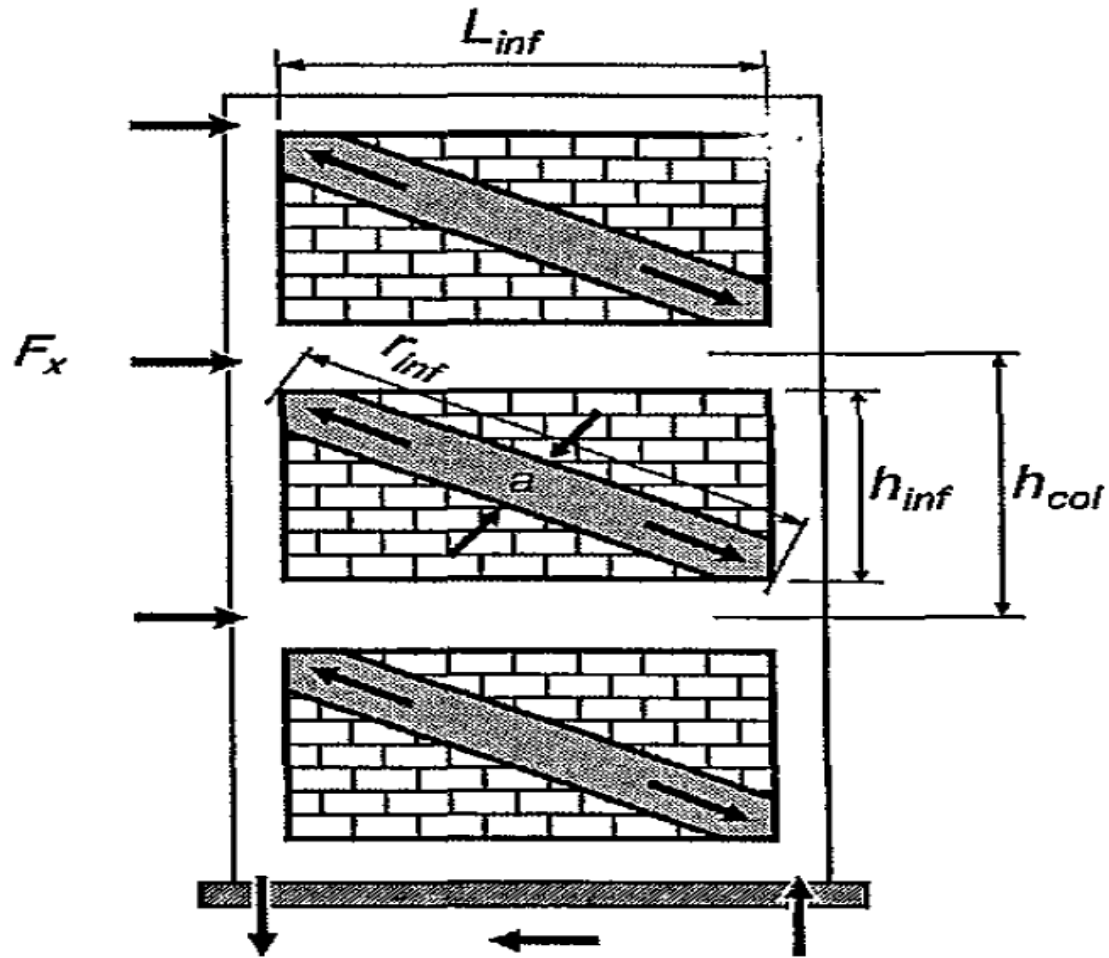

Compression Strut Analogy

Equivalent Strut Method Calculations

- Formulations is taken from ASCE 41-06
- For calculations of depth of strut

$$a = 0.175(\lambda_1 h_{col})^{-0.4} r_{inf}$$

$$\lambda_1 = \left[\frac{E_{me} I_{inf} \sin 2\theta}{4E_{fe} I_{col} h_{inf}} \right]^{\frac{1}{4}}$$

- Strength of strut in compression only

$$N_{comp} = \frac{A_{inf} f_s \sin \theta}{\cos \theta}$$

- Strength of strut in case of RCC wall

$$N_{ten} = \frac{A_s f_y s L_{inf}/s}{\cos \theta} \quad N_{comp} = \frac{A_{inf} f_s \sin \theta + A_c 3.3 \sqrt{f_c}}{\cos \theta}$$

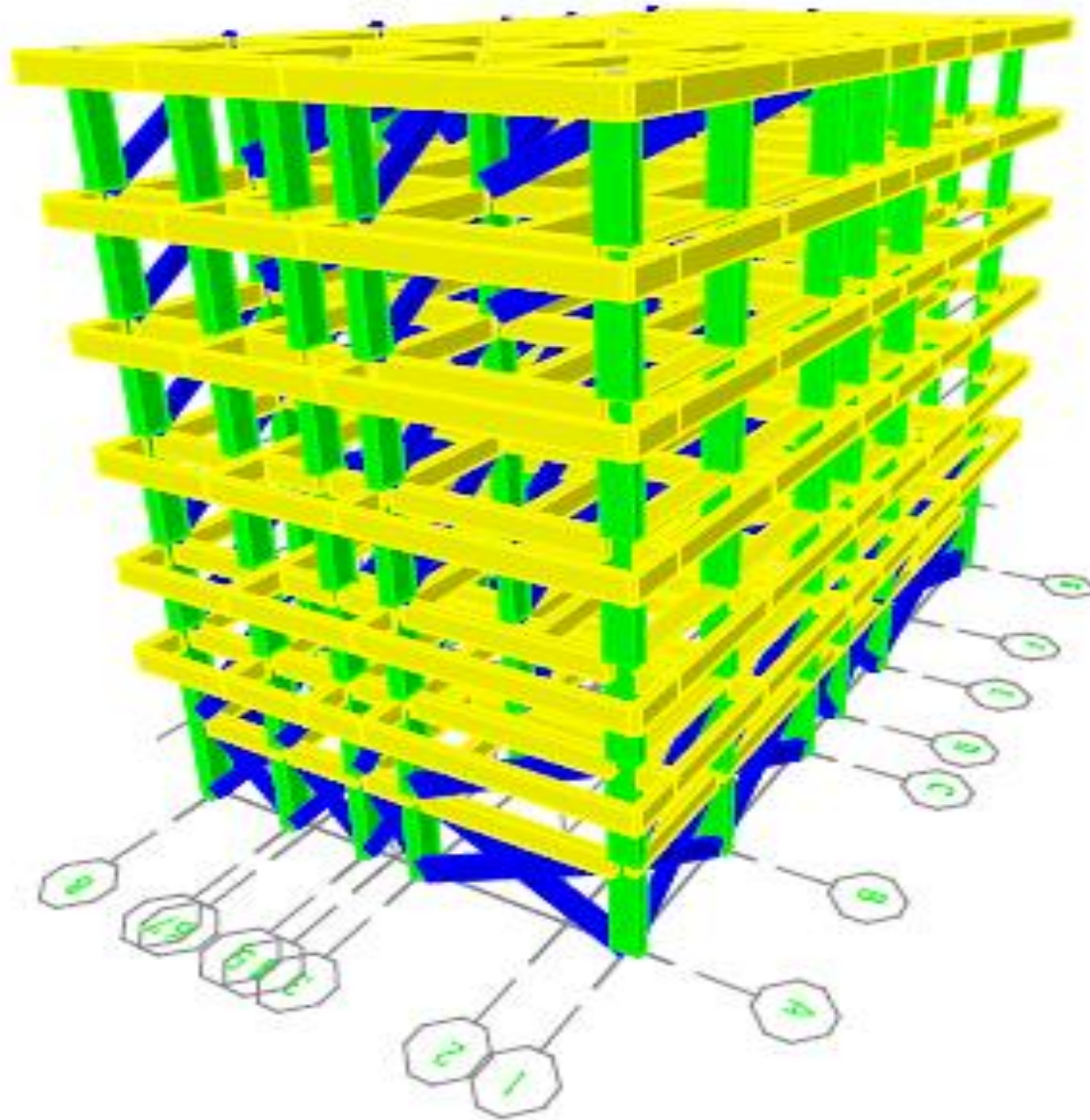

3D Model from ETABS with infill walls as struts

Linear Analysis

- Performed to check the building behaviour near the yield point
- To understand the building capacity to resist the seismic forces, few checks as per ASCE 31-03 were done. These checks included

- Torsional Irregularity = $\frac{CM-CR}{\text{Total length in X or Y}} < 0.2$

- Drift $\Delta m = 0.7 \times R \times \text{DRIFT} > 0.02$

- Soft story Story Stiffness = $\frac{\text{Force in X or Y direction}}{\text{Relative floor displacement}} < 0.7$

Linear Analysis

- Weak story = $\frac{\text{Total loads in a story in X or Y direction}}{\text{Adjacent story loads in X or Y direction}} < 0.8$
- Mass irregularity
Ratio of consecutive story mass = $\frac{\text{Story mass}}{\text{Adjacent story mass}} > 0.5$
- Column Capacity $\frac{V_u}{V_n} < 1.0$
- Beam capacity $\frac{M_u}{M_n} < 1.0$

Linear Analysis Results

Results of the checks performed in linear analysis are as follows

➤ Torsional irregularity Check

For X-Direction : Span L = 470 in						
Story	XCM(in)	XCR(in)	P=(XCM-XCR)(in)	P/L	Allowable limit	Result
Roof	237.863	345.602	-107.74	0.22923	0.2	Not OK
Fifth Floor	242.102	343.552	-101.45	0.21585	0.2	Not OK
Fourth Floor	240.494	341.853	-101.36	0.21566	0.2	Not OK
Second Floor	242.102	339.291	-97.189	0.20679	0.2	Not OK
First Floor	242.002	330.759	-88.757	0.18884	0.2	OK
Mezzanine	232.569	304	-71.431	0.15198	0.2	OK
Ground Floor	250.301	255.894	-5.593	0.0119	0.2	OK

It was observed that the torsional irregularities existed. Hence the eccentricities were enhanced with help of amplification factor in X and Y direction.

$$e_x = 0.0578 \text{ and } e_y = 0.0617$$

➤ Drift Check

Story	Δm in X-Direction		Allowable Limit	Check
Roof	0.0082516	<	0.02	OK
Fifth Floor	0.01333535	<	0.02	OK
Fourth Floor	0.01784825	<	0.02	OK
Second Floor	0.0229761	>	0.02	NOT OK
First Floor	0.0290913	>	0.02	NOT OK
Mezzanine	0.01329615	<	0.02	OK
Ground Floor	0.00031115	<	0.02	OK

➤ Soft Story Check

Story	Load	U(in)	ΔU (in)	V(kip)	K(kip/in)	Stiffness ratio	
Mezzanine	EQX	0.5009	0.4892	-765.5	1564.8	0.67	Soft Story in X-direction
Mezzanine	EQY	0.3643	0.3576	-791.3	2212.8	0.66	Soft Story in Y-direction

- No Weak story was found in both X and Y direction
- No Mass irregularities existed in both X and Y direction
- Beam and Column sections capacity

Story	No. of Beams		No. of columns	
	Passed	Deficient	Passed	Deficient
Roof	100%	NIL	100%	NIL
Fifth floor	88%	12%	100%	NIL
Fourth floor	75%	25%	100%	NIL
Second floor	72%	28%	88%	12%
First floor	58%	42%	12%	88%
Mezzanine	47.5%	52.5%	NIL	100%
Ground floor	78%	22%	96%	4%

Comparison of Results With and Without Infill's Contribution

➤ Beam and Column capacity comparison

Story	No. of deficient beam without infill's	No. of deficient beam with infill's
Roof	6	NIL
Fifth floor	26	12
Fourth floor	31	21
Second floor	34	27
First floor	34	33
Mezzanine	31	31
Ground floor	7	4
Story	No. of deficient column without infill's	No. of deficient column with infill's
Roof	3	NIL
Fifth floor	10	NIL
Fourth floor	15	NIL
Second floor	18	3
First floor	23	22
Mezzanine	25	25
Ground floor	4	1

➤ Story drift comparison of the model with infill's and without infill's contribution

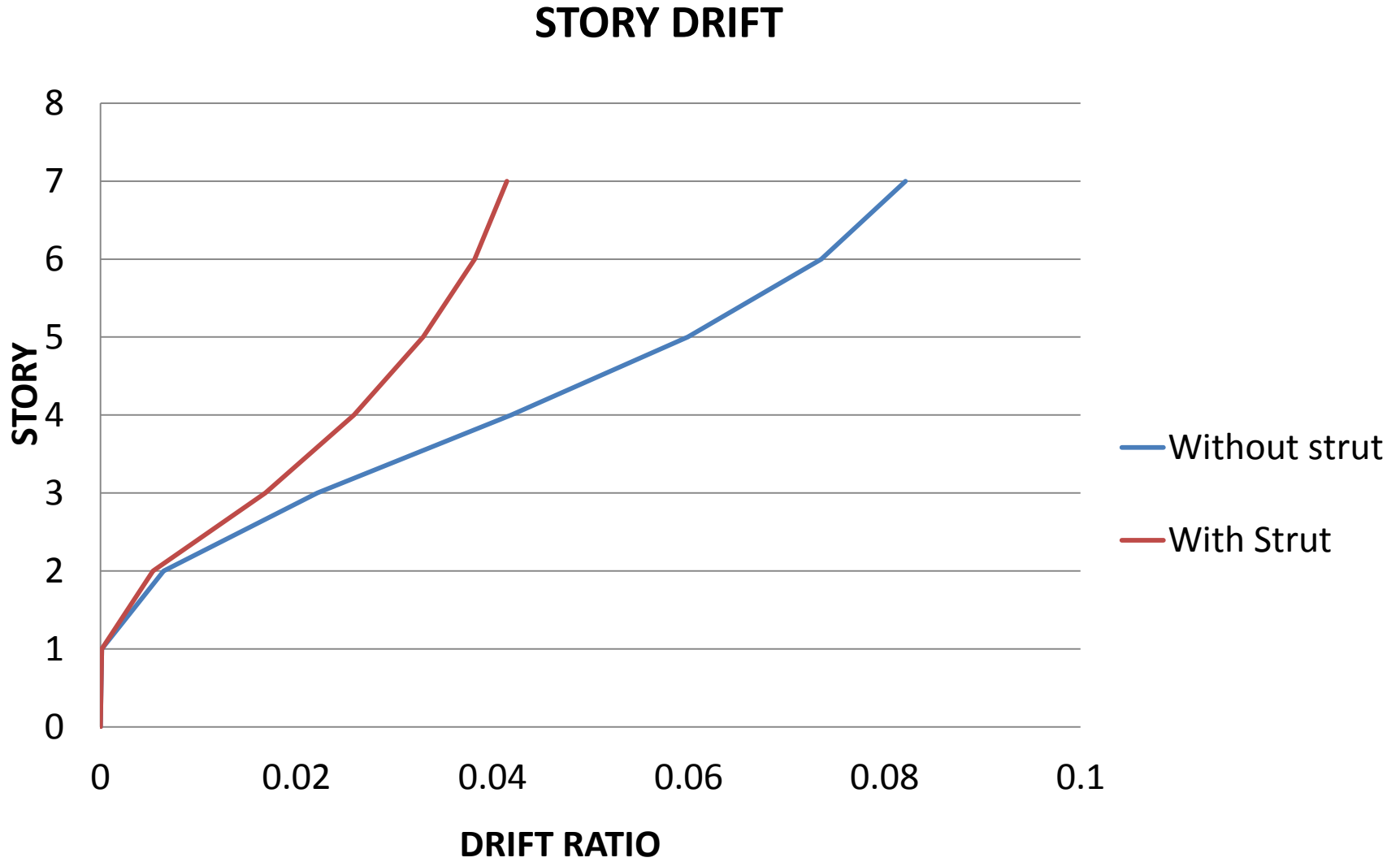

Non-Linear Analysis

- Number of Beam and Column sections that were found to be deficient in linear analysis, were further analyzed in nonlinear analysis

Push Over Analysis

- Is a technique by which a structure is subjected to an incremental lateral load
- With the sequence of yielding and plastic hinge formation, failure of building members are noted
- An iterative analysis which goes on until a pre-established criteria is satisfied
- An attempt to evaluate the real strength of the building by utilizing the full capacity of the building members

Plastic Hinges

- Plastic hinges are the yield capacity of a member that can be used to monitor which member goes to the nonlinear portion, and shows the acceptance criteria of the member
- Plastic hinges had been defined and assigned for the following building members
 - Beams
 - Columns
 - Struts
- Yield moment capacity of the Beam and Column were computed from Response 2000
- Plastic rotations and Acceptance criteria for Beams and Columns have been taken from ASCE 41-06 based on “percentage of Steel”, “Shear force” and “axial load”
- Plastic Displacement and Acceptance criteria for Struts have been taken from ASCE 41-06 based on infill dimensions

M- ϕ Curve for Pushover Hinge

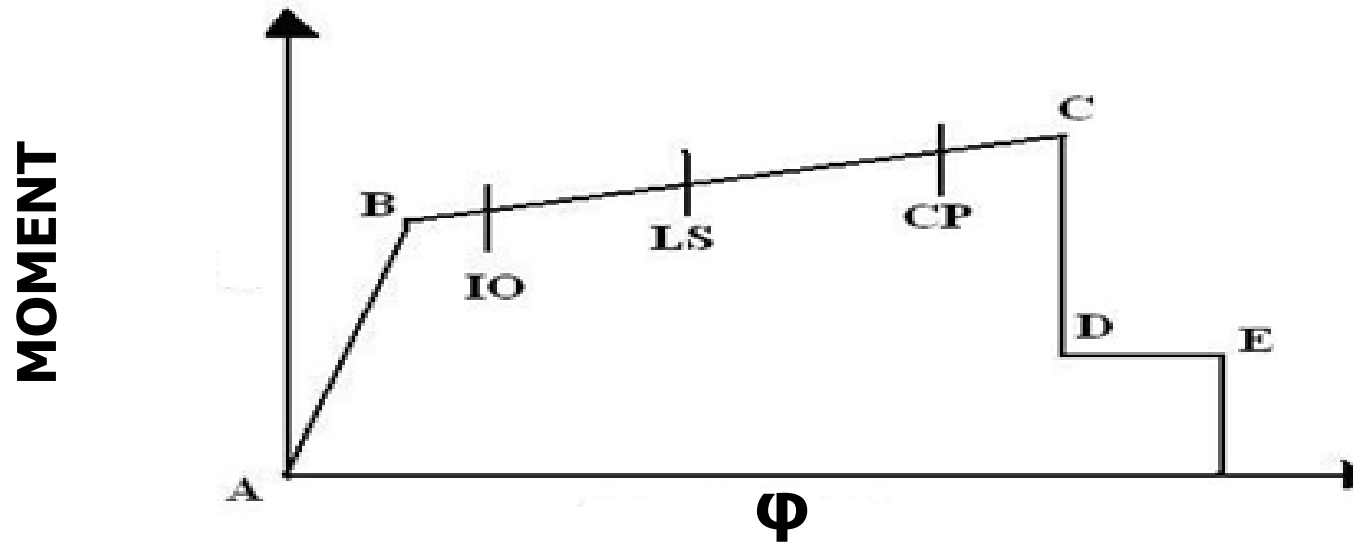

- Point A= origin
- Point B= yielding
- Point C= ultimate capacity
- Point D= residual strength
- Point E = failure

Capacity Spectrum Method

- To apply pushover analysis, capacity spectrum method was used
- Demand versus capacity curve is plotted with intersection of the two curves indicating the performance level of the building

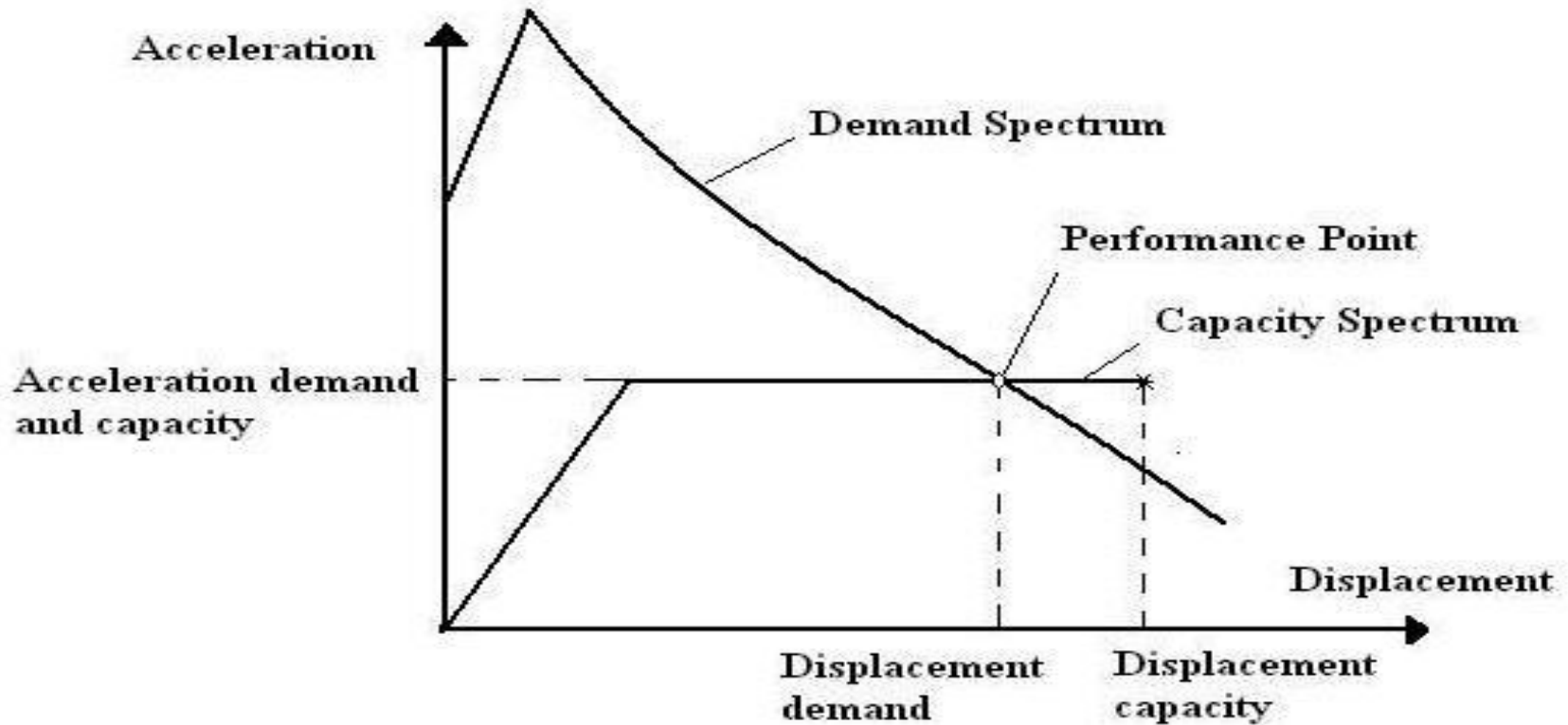

Static Pushover Analysis Curves

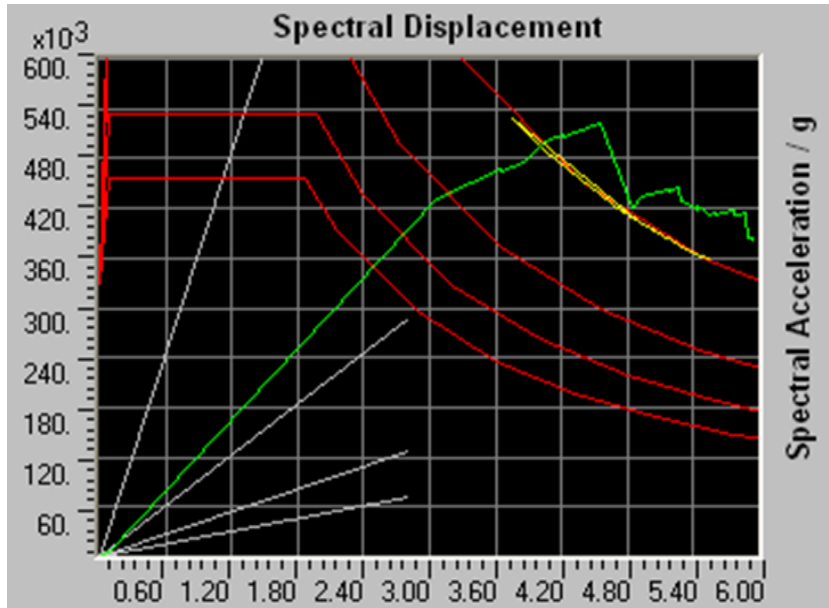

Pushover curve in X-Direction

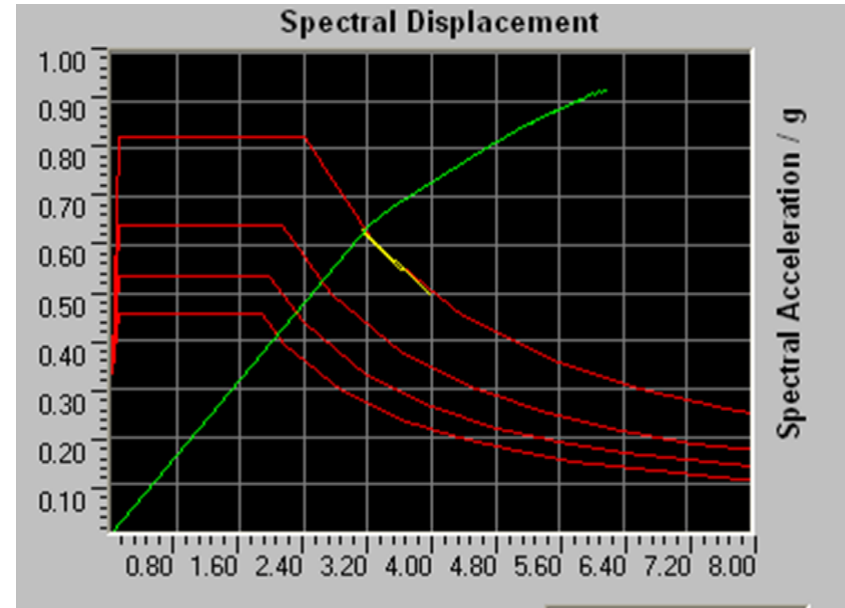

Pushover curve in Y-Direction

- At Performance point , T_{eff} (effective time period) was 0.910 and 0.718 for Push-X and Push-Y respectively
- Performance point met at step 7 and step 3 for Push-X and Push-Y respectively
- Every beams and columns hinges was checked at these steps whether they exceeded the performance level (LS) or not

Pushover Analysis Results

- 80 beam sections and 2 column sections exceeded the performance level in nonlinear analysis

Deficient Columns

Column ID	Location	M 3-3 Kip-ft	M 2-2 Kip-ft	My Kip-ft	1.1My Kip-ft	M at LS Kip-ft	ΔM
C23	G-1	-131.2	-554.65	511.8	562.98	554.45	-0.2
C24	G-2	-94.75	-566.55	519.6	571.56	562.9	-3.65

Pushover Analysis Results

continue Non-Linear Analysis....

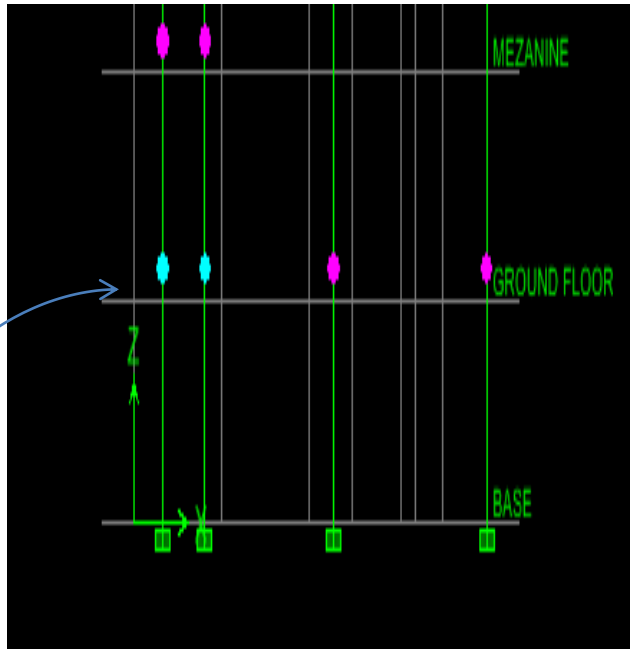
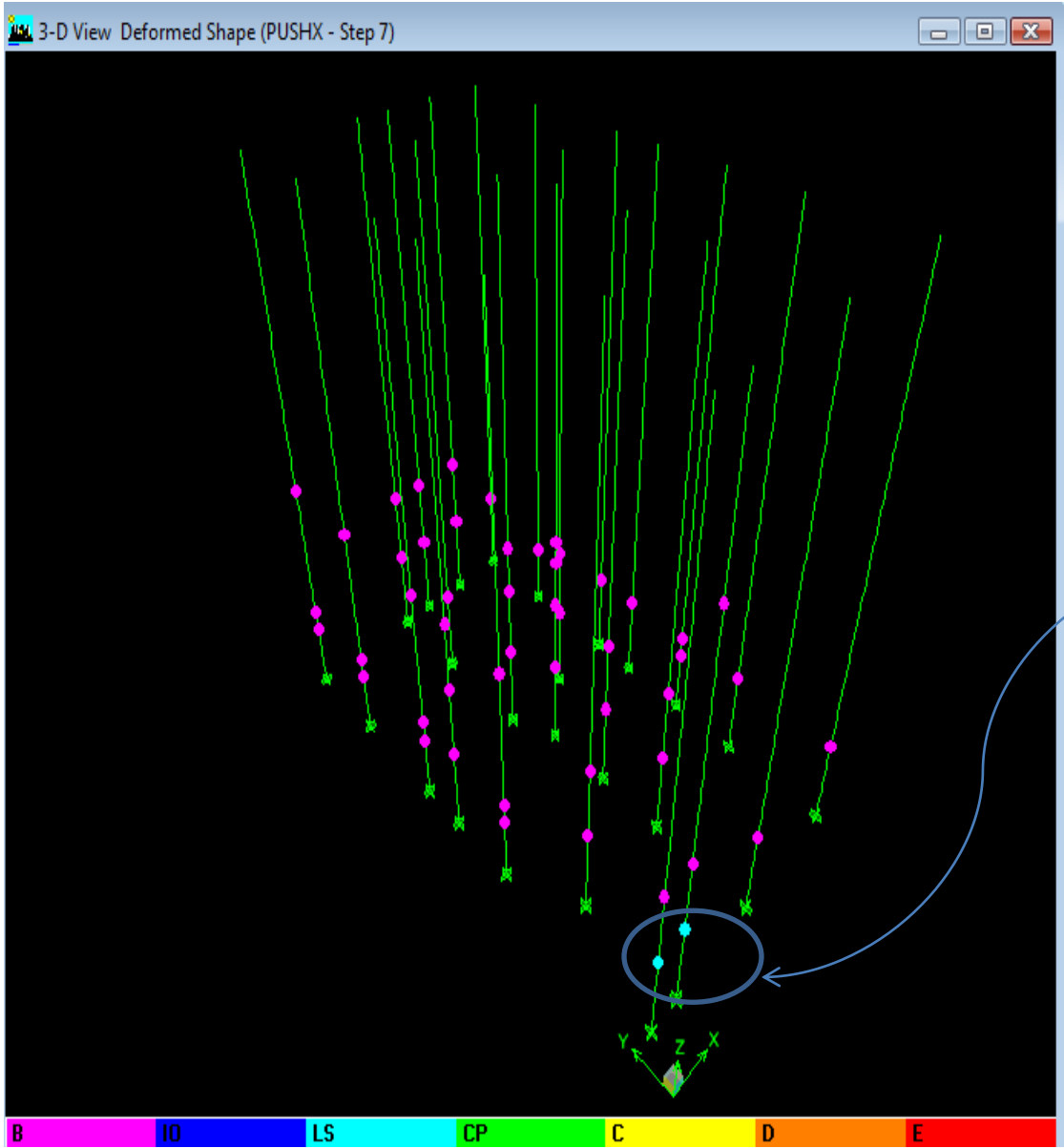

Deficient Beams

Story	Beam Type	Performance Level	No. of Beams deficient
Ground Floor	Primary	-	Nil
	Secondary	-	Nil
Mezzanine	Primary	>LS	19
	Secondary	>LS	3
First Floor	Primary	>LS	16
	Secondary	>LS	7
Second Floor	Primary	>LS	6
	Secondary	>LS	7
Fourth Floor	Primary	>LS	4
	Secondary	>LS	6
Fifth Floor	Primary	>LS	5
	Secondary	>LS	7
Roof	Primary	-	Nil
	Secondary	-	Nil

Pushover Analysis Results

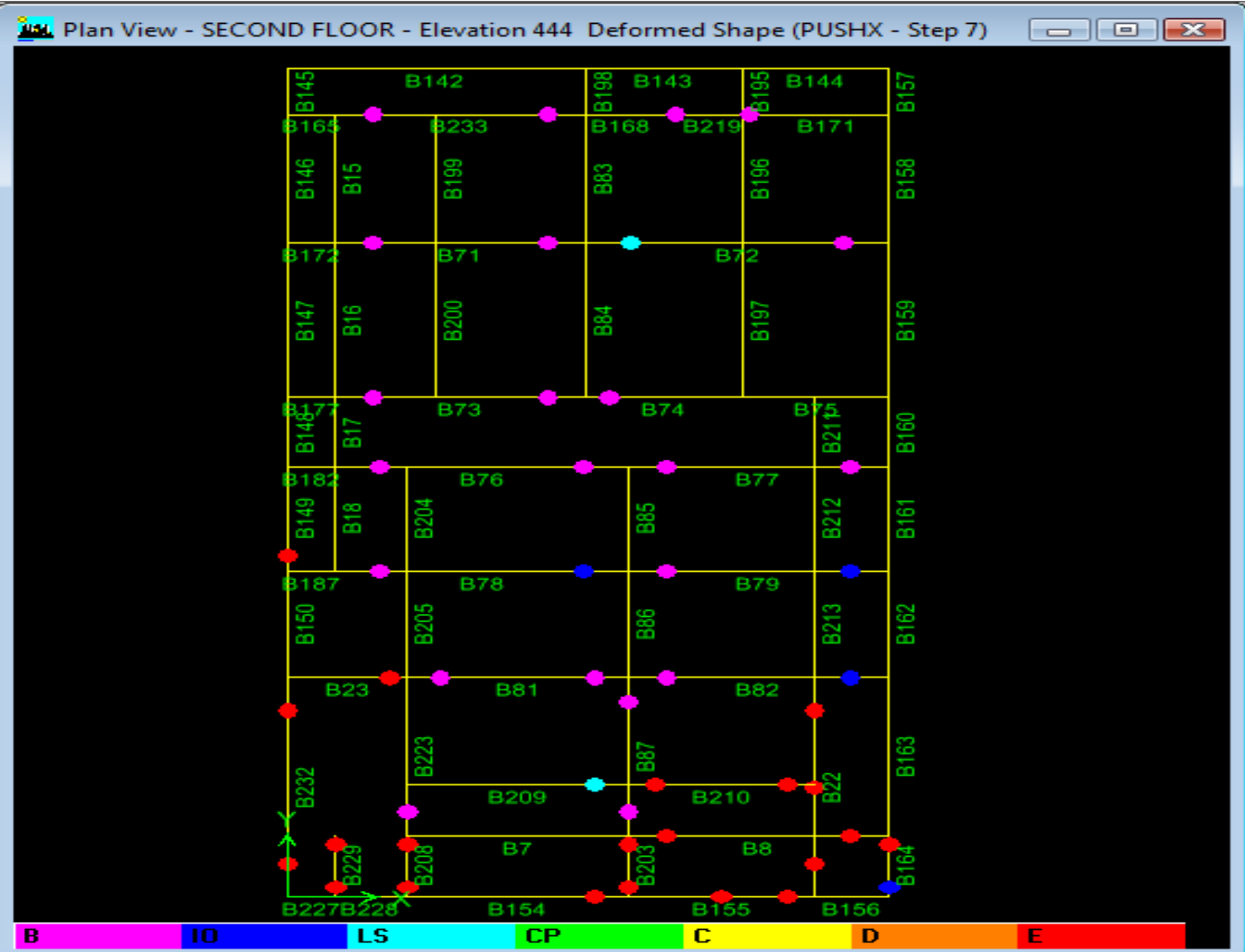

Comparison Between Linear and Non-linear Analysis

- Comparison between deficient beam sections in Linear analysis and Non-Linear analysis

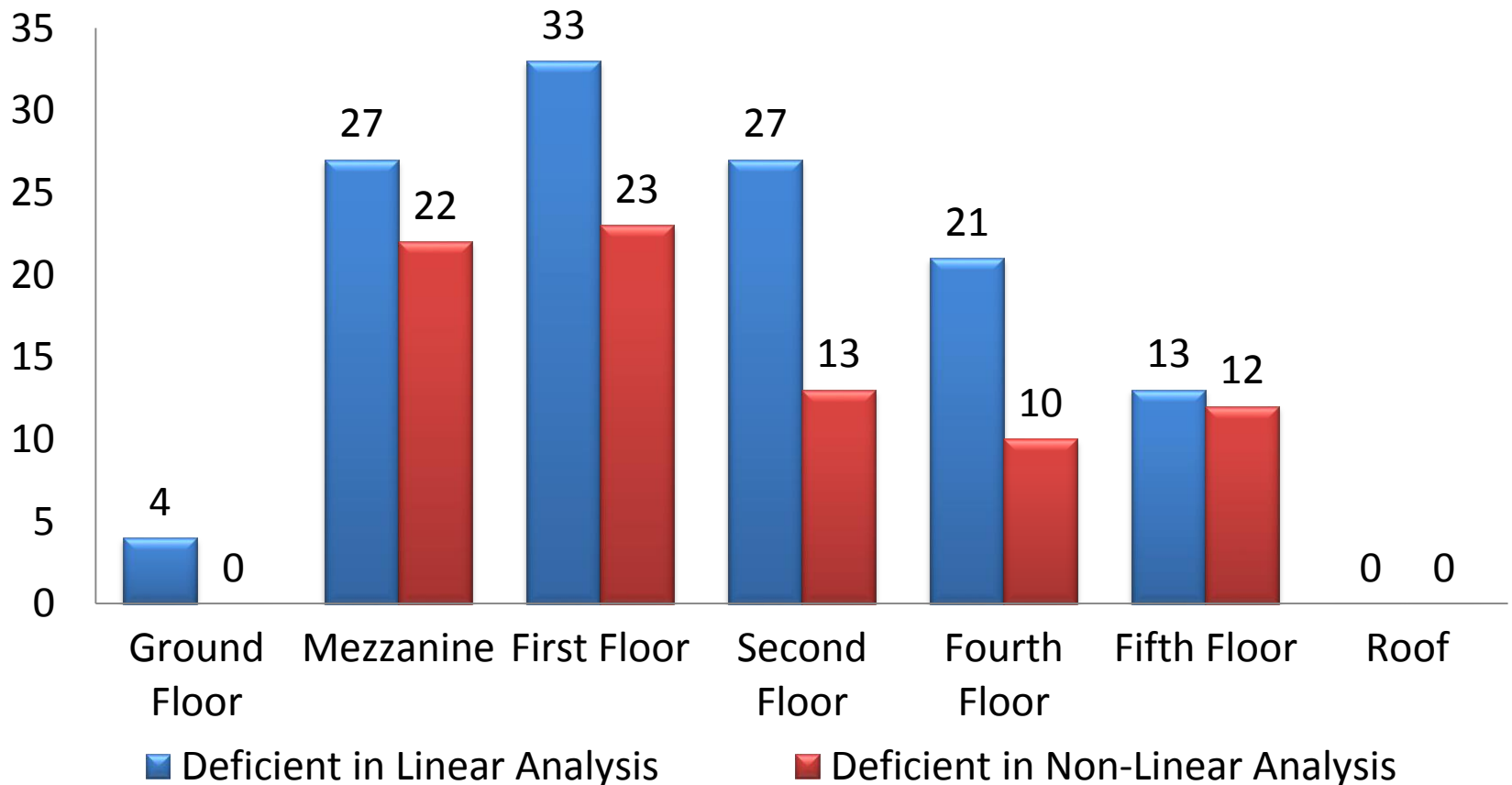

Retrofitting

- To increase the strength of the member
- To increase the stiffness of the member

Proposed Retrofitting Technique

Concrete Jacketing

- A common technique
- Increases the member cross section
- Enhances the capacity of flexural strength and shear strength
- Employed as the contractors have the knowledge about it

Details Of Retrofitted Beams

- Enhanced the moment capacity by hit and trial method up to the Performance Level (Life Safety)
- Five Beam sections were required for retrofit

Story	Beam ID on ETABS	Initial My	Required Moment	Enhanced My
Mezzanine	B203	93.6 k-ft	118.46 k-ft	130 k-ft
First Floor	B203	93.6 k-ft	117.22 k-ft	110 k-ft
Second Floor	B203	93.6 k-ft	115.7 k-ft	110 k-ft
Fourth Floor	B203	93.6 k-ft	115.83 k-ft	110 k-ft
Fifth Floor	B203	93.6 k-ft	98.7 k-ft	110 k-ft

Proposed Beam Sections

Proposed Section For $M_y = 130$ k-ft and $M_y = 110$ k-ft

- Section depth increased up to 6-inch and 4-inch
- Longitudinal Reinforcement 3 # 8 bars and 3 # 5
- Concrete strength 4250 psi
- Capacity of Proposed Beam Section is $M_y = 133.2$ k-ft and 115.2 k-ft.

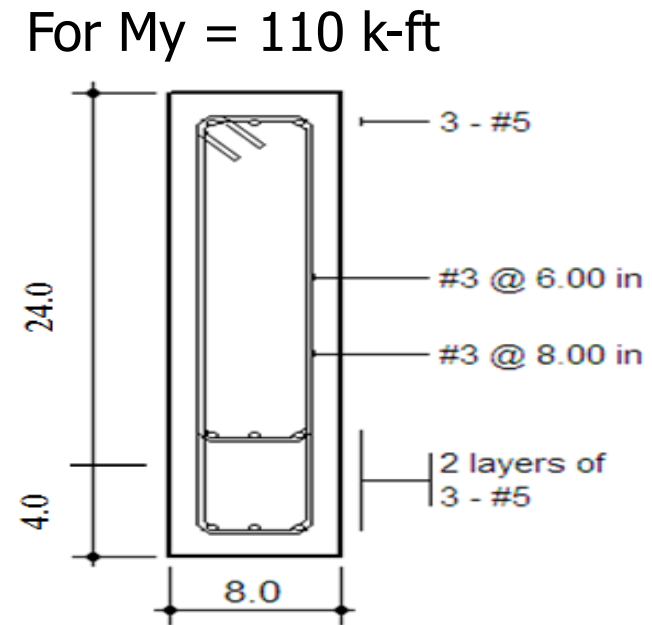
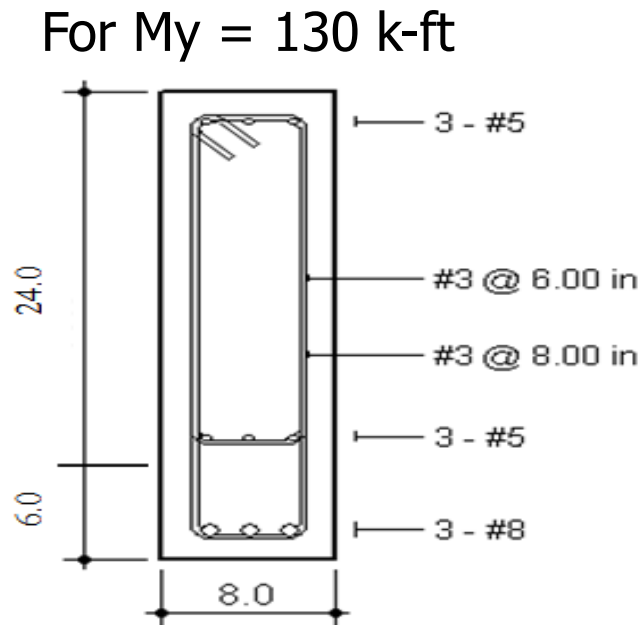

Before Retrofitting of Beams

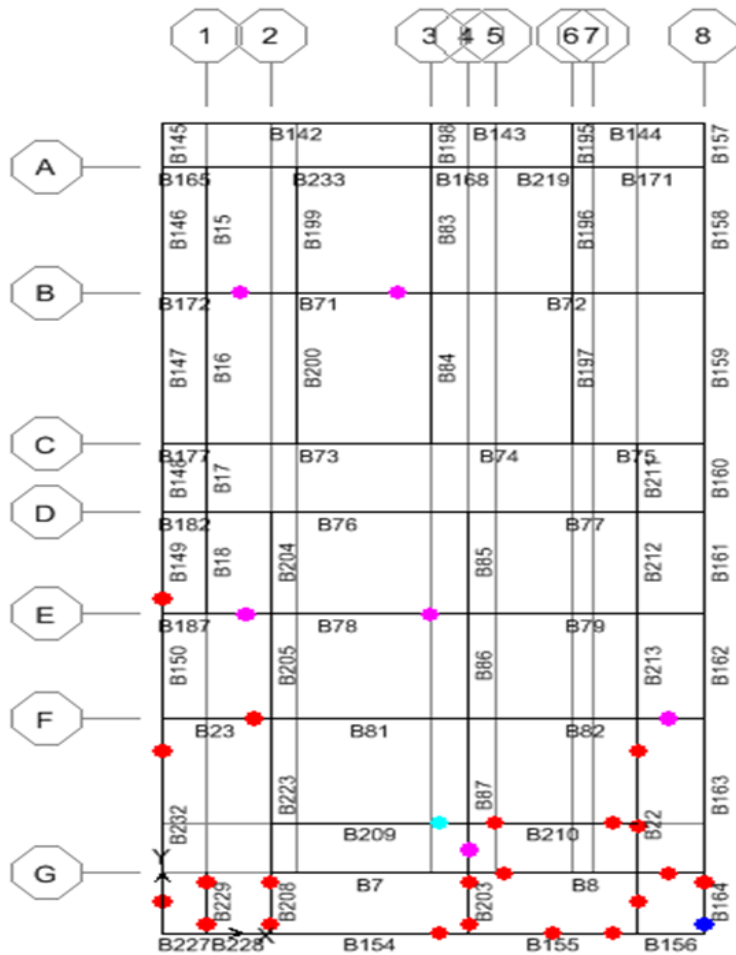

After Retrofitting of Beams

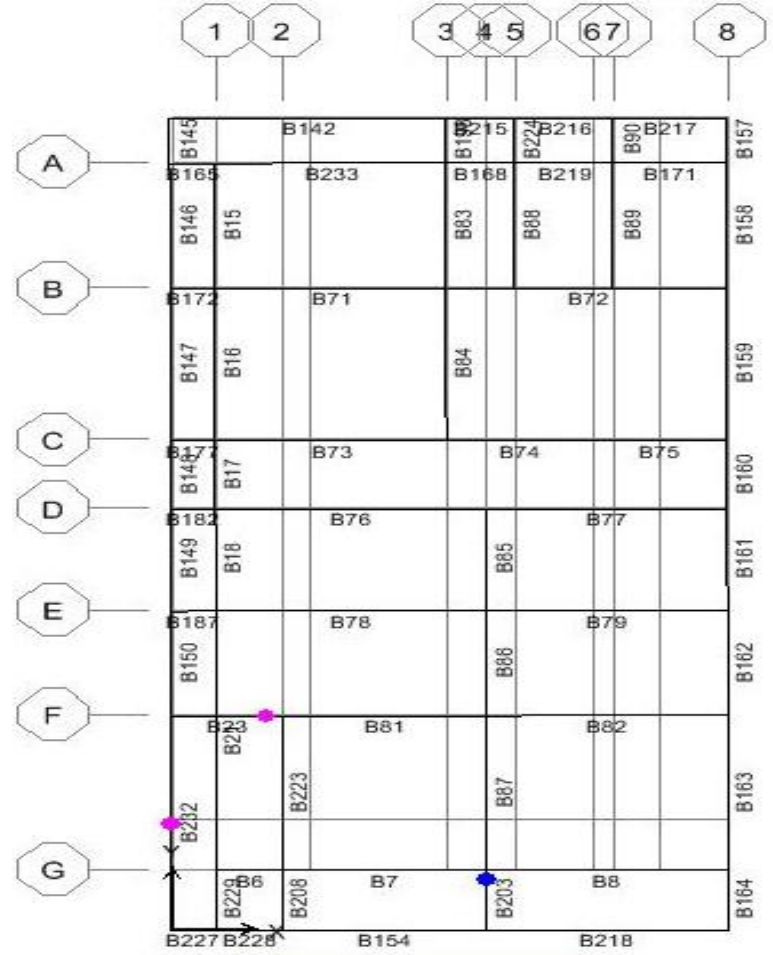

Legends

- b/w yield point and IO
- Immediate Occupancy
- Life Safety
- Collapse Prevention
- Near to Failure

Retrofitting Of Columns

- After Retrofitting of beams section, analyzed the structure in the non-linear
- The Performance point was obtained at step 1
- No column found was deficient as no additional moment distributed from beam to column

Column ID	Applied Moment M 3-3 (k-ft)	Applied Moment M 2-2 (k-ft)	Yield Moment Capacity My (k-ft)
C23	-35.91	-38.59	511.8
C24	-27.89	-32.09	519.6

- No need to retrofit

Push Over Curves

- After Retrofitting, all members were within the performance level (Life Safety)

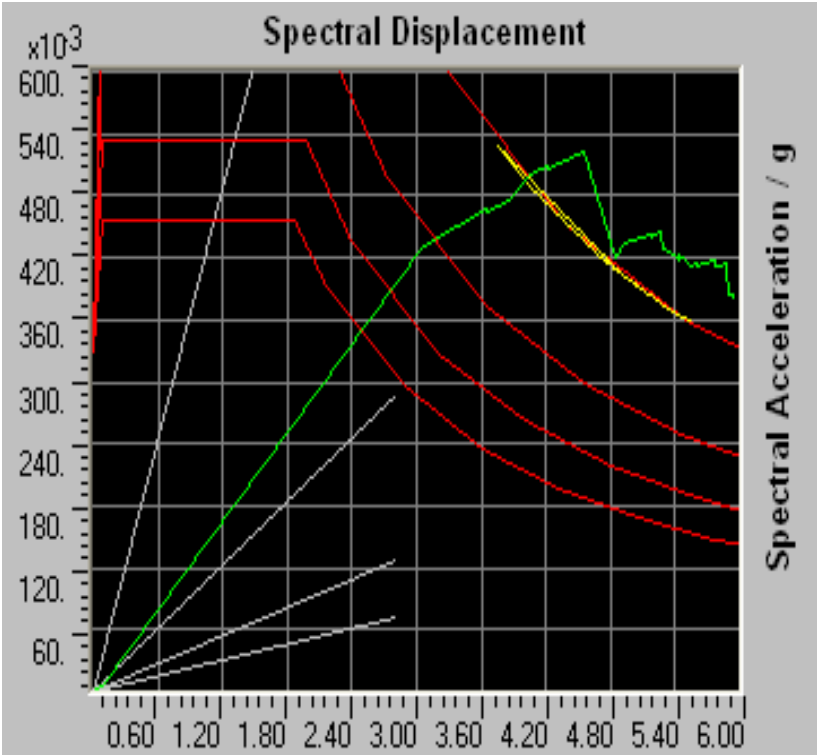

Before Retrofitting

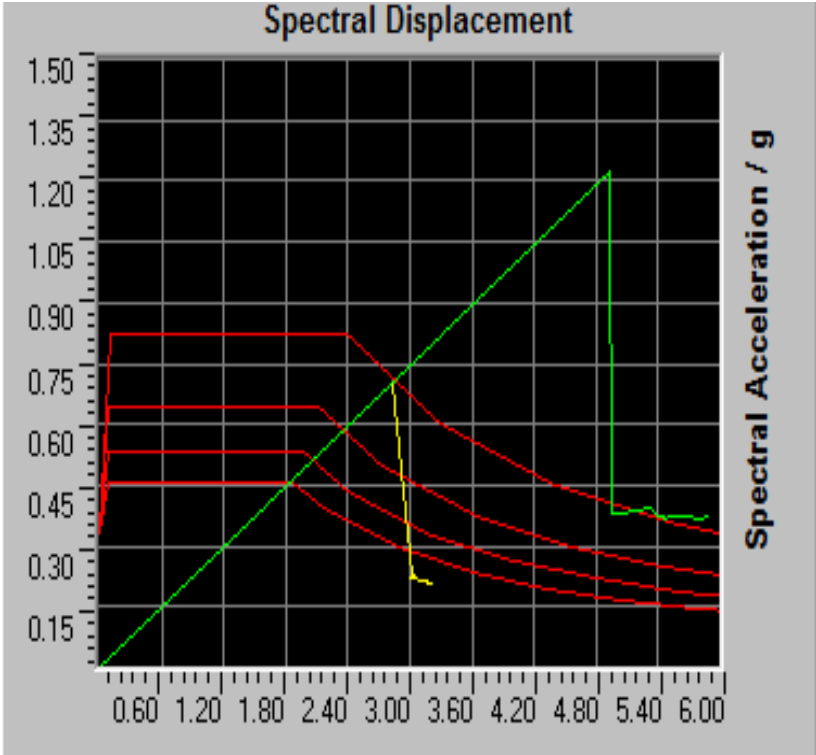

After Retrofitting

Pushover curve for Push X case

Conclusion

- Capacity of number of beams and columns in linear analysis is inadequate to resist the applied loads whereas in non-linear case the deficient number of beams and columns had been significantly reduced
- Number of deficient columns were less while analyzing the building with infill walls as compared to without infill walls
- Application of Performance Based Design approach reflected a clear view of the building behaviour when analysed for Life safety

continue.....

Conclusion

- By utilizing the non linear capacity of the members and providing acceptable levels of earthquake damage to the building , can provide safety to rest of the buildings elements
- In retrofiting, after increasing the yield moment capacity of five beam sections, all beams and columns fulfilled the limitations of performance level (LS)
- Concrete Jacketing approach was proposed for retrofiting

Acknowledgement

1. Dr. Abdul Jabbar Sangi
2. Anum Raza
3. Hafiz Muhammad Zohaib Kabir
4. Tehniat Tanveer
5. Hafiz Muhammad Rashid Mohiuddin
6. Syed Ahmed Raza

THANK YOU